

## G1/G17 Series

### Series-Active Sealed Tact Switch



#### ■ Features

- Water and Dust Proof(IP67) Design
- Long life/High Reliability
- 0.8\*0.8PCB terminal
- Operate the two levers at the same time for safety operation
- Variety of levers and control methods
- Mini size, could be used for tight space

#### ■ Application

◆Auto

◆Industry control

#### ■ Parameters

Rating		12VDC 20 $\mu$ A <sup>~</sup> 20mA
Operating Frequency	Electrical	20 cycles/minute
	Mechanical	G1 Series:120 cycles/minute G17 Series:80 cycles/minute
Contact Resistance(Initial Value)		<200m $\Omega$
Insulation Resistance(at 500VDC)		>10m $\Omega$
Vibration durability		10~55Hz, Amplitude 1.5mm
Voltage Resistance	Between Terminals	500VAC (50~60Hz)
	Between terminals and housing	1500VAC (50~60Hz)
Service Life	Electrical	100,000 cycles
	Mechanical	100,000 cycles
Storage Temperature		-40° C~+85° C
Storage Humidity		85%RH MAX
Unit Weight		G1:0.85g
		G17:1.1g

## ■ Shape

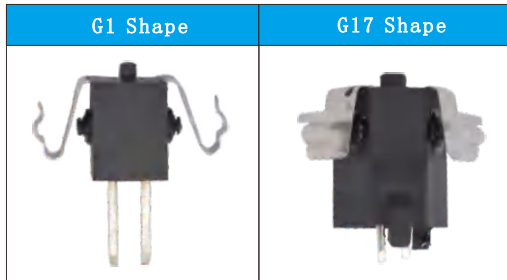

## ■ Circuit Configuration

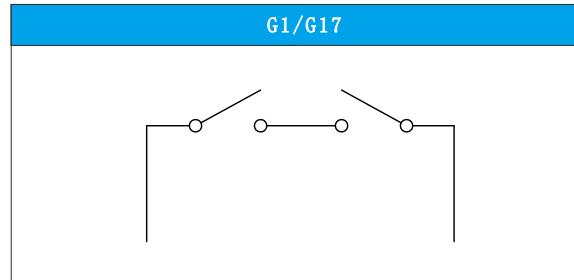

## ■ G1 Dimension

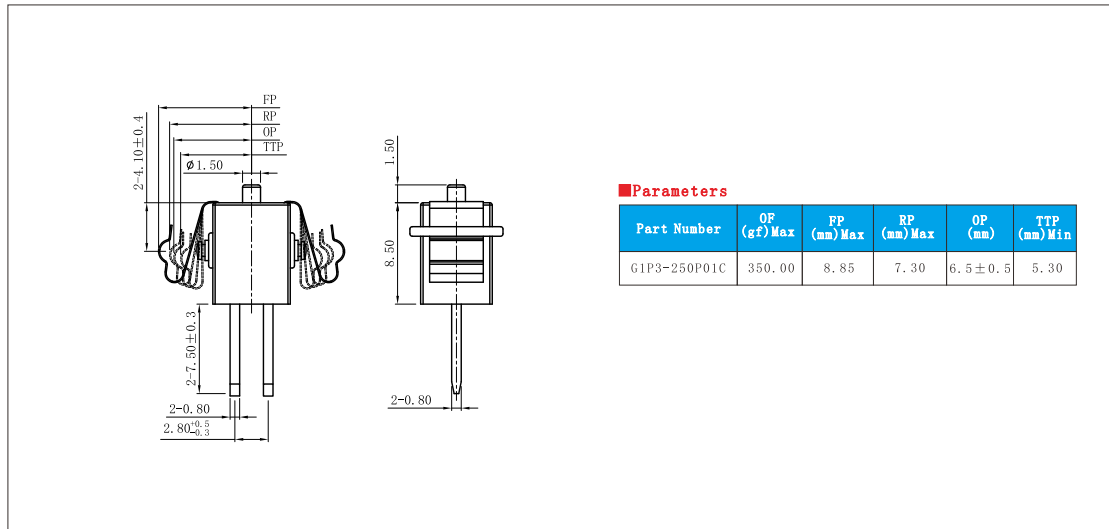

## ■ G17 Dimension

